

Access for Windows 5250 Release 4.20

Access for Windows 5250 is Eicon Technology's PC-to-midrange connectivity solution for Microsoft® Windows 3.x. Access for Windows 5250 is well integrated with Microsoft® Office™ and Microsoft® BackOffice™ applications making it the business user's solution for quick and easy access to host information. With its intuitive interface, innovative connection management, multi-session architecture, and built-in support for a wide range of industry-standard APIs, Access for Windows 5250's powerful features meet the needs of all users, from the computer novice to the seasoned expert.

Access for Windows 5250 is designed to be network independent, and it supports a wide range of SNA and TCP/IP connections, including all major SNA LAN gateways. It offers fast file transfers, WOSA-compliant WinAPPC and WinHLLAPI support, easy installation and configuration, and LAN-based distribution. Access for Windows 5250 offers corporations a long term connectivity solution that yields reduced training and support costs.

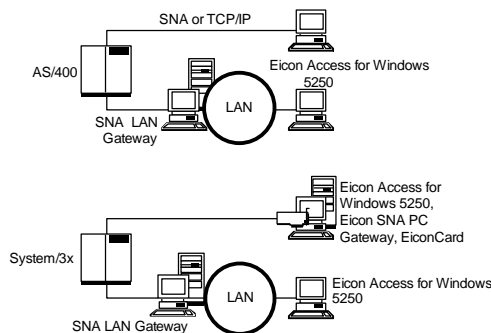

Eicon Access for Windows 5250 provides Microsoft Windows 3.x users with seamless access to midrange applications

■ Product Highlights

- IBM 5250 and tn5250 display emulation
- IBM 5256 and 3812 printer emulation
- Eicon AS/Router™ provides TSR-free full stack and split stack connections to AS/400 computers across many gateways, direct LAN connections, and TCP/IP backbones
- Next-generation TCP/IP connectivity with Eicon's Desktop DLSw™ (RFC 1795 and 1434)
- Compatible with Windows 3.x, WFW 3.11 and Windows 95

What's in it for MIS Managers?

MIS Managers are concerned with protecting their current investment. Access for Windows 5250 helps MIS Managers protect their investment because it runs on both Microsoft Windows 3.x and WFW 3.11, as well as Microsoft Windows 95. Corporations migrating to Windows 95, or corporations with a mixed installed base of Win16 and Win32 desktops can benefit from Access for Windows because they would not need to upgrade their emulation package immediately, and can standardize on one emulation package across the enterprise.

Today's MIS Managers need to make the most of their existing legacy applications. Access for Windows offers corporations numerous connectivity options that provide the flexibility needed for multi-protocol networks. Corporations can standardize on one emulation product no matter what LAN or WAN protocols are being used in each remote office, providing economies of scale for training and support requirements, and ultimately, decreasing the total cost of ownership.

<i>Feature</i>	<i>Benefit</i>
International Support	International keyboard and font support in 26 languages allows large multi-national corporations to standardize on one emulation product for worldwide host connectivity.
Multi-language support on one CD	MIS can buy one product, select a language in which to work, and make additional languages available to their users on the LAN. Access for Windows is available in an international version called "Access for Windows International Edition". English, French, German, Italian and Spanish language versions of the program are all included on one CD. Greek, Cyrillic, Turkish, and Central and Eastern European font and keyboard support is also included on the same CD.
Integrated ISDN Connectivity	This unique feature allows remote stand-alone and nomadic workers to use ISDN to reach the host without intervening gateways or routers! An Eicon Diva adapter is needed. The application can be configured to use ISDN with an 802.2 LLC interface but the underlying transport is actually the ISDN protocol.
SNA over Frame Relay	This is a feature of Eicon Technology gateways that is unique. When selling Access for Windows into an Eicon Gateway environment it is a major advantage if they plan to, or already need Frame Relay support.
Desktop DLSw™	This unique feature allows for native SNA to traverse across an IP backbone, not compromising SNA as tn5250 does, allowing for all SNA (5250, APPC, printing) connections. This is an open solution, and it is included as a standard feature in Access. Settling on TCP/IP as a WAN and a LAN protocol greatly reduces support costs and simplifies network management.

AS/Router™	The AS/Router provides a number of compelling benefits MIS Managers. One of these benefits is that any connection going through it is a complete DLL-based solution, that does not occupy any of the lowest 640K of memory used by DOS. This allows more room for other applications, and simplifies the management of AUTOEXEC.BAT and CONFIG.SYS files. Also, because it's a Windows program, it is more reliable, eliminating the interaction between DOS and Windows for APPC communications. AS/Router™ gives MIS the options of connecting via a full stack (for direct or TCP/IP connections) or of sharing the stack with a gateway, allowing LU concentration and flexible configurations in a multi-user environment.
Multiple AS/400 Support	The AS/Router™ allows client PCs to reach multiple AS/400 hosts concurrently across a variety of host link types (unlike PC Support/400). This allows flexible connection to multiple destinations, allowing it to be seamlessly integrated into client-server architectures with multiple SNA destinations.
Extra options as standard features	Dynamic Data Exchange (DDE) and Application Programming Interfaces (APIs) are integrated in the package as standard features where many competitors offer them as extra add-on options at hundreds of dollars more!
WinHLLAPI	Enables third-party Windows applications that are written to this API to communicate with Access for Windows and provides a "front-end" to the user interface.
WinAPPC	Enables third-party Windows applications that are written to this API to communicate with Access for Windows
EHLLAPI	Enables third-party DOS applications that are written to this API to communicate with Access for Windows
AFWAPI	Makes it easy to write Visual Basic or C applications. Examples of Visual Basic applications are included in the package
Access Tools for ProMacro	Enhanced macro language for corporate MIS Managers that includes a macro editor, a compiler and a dialog editor (sold separately). Compiled ProMacros can be run from within Access from the Run ProMacro command found under the Macro menu.

What's in it for LAN Administrators/Help Desk?

Access for Windows includes a bunch of features that allow LAN administrators to automate and pre-set the end user access to host information in order to increase productivity and ensure security. Features that provide easy roll-outs and minimal training requirements help make their job easier. Access for Windows provides the facilities to automate roll-outs, customize the user's desktop in advance, thereby cutting down on calls to the Help Desk.

<i>Feature</i>	<i>Benefit</i>
SMS Support	Provides scripts that allow attended or unattended installations of Access across the network using Microsoft Systems Management Server 1.1 saving time and headaches.
Customization Utility	Allows the LAN administrator to control end-user's access or use of specific menus and menu items.
Un-install Utility	Cleanly removes existing Access software from .INI files and system registries.
LAN File Server Installation	Provides access to all of the PCs attached to the network, saving time for the LAN administrator, and available disk space on the end user's PC.
Graphical Toolbar Editor	Lets LAN Administrators add, move, remove or rename menus. The process of editing a menu or toolbar item is identical to that of standard Microsoft® Office™ products. This feature is useful for system administrators who want to pre-set users' configuration to either help them choose the functions that they need, or to control what functions for which they have access.
Dynamic Session Back-up	Minimizes the help desk calls, by re-routing the failed sessions through alternate SNA resources (other gateways or types of connections).
Multiple Document Interface	Makes it easy for users to manage their sessions, especially in multiple session environments. These windowed sessions can be minimized, maximized, tiled or cascaded. Display and printer sessions can be displayed side by side. Allows up to 32 concurrent sessions.
Single Document Interface	Multiple instances of Access can also be open (up to 12) with multiple sessions open inside of each instance.
Host Color Remapping	Lets LAN administrators customize the user interface so it becomes transparent to their legacy application.

TSR-free Workstation

All connectivity options are either DLL or VxD based, which means that no conventional memory is used with these connection types, providing the user with better response times, and the ability to have more applications open. Access for Windows 5250 connections are TSR-free except older Eicon gateways (before V3R1a), Novell NetWare for SAA (DOS router), and Twinax connections.

What's in it for End Users?

The Access for Windows 5250 trademark is the ease with which users can access host applications. With its intuitive user interface and carefully designed installation and configuration programs, Access for Windows 5250 lets users get up and running with the product with virtually no training, and no costly learning curve.

Productivity boosters like the intelligent cut and paste, macro-recording, type-ahead support and softkeys let users perform complex actions with a single click. Features like the graphical toolbar and toolbar editor help make users as comfortable with Access as they are with their Microsoft Windows applications.

Feature	Benefit
Graphical Toolbar	Easy one-click access to menu bar items that can be customized. Bell and whistle item that lets users feel as comfortable as they do in their other Windows applications. Features ToolTips that display a descriptive text for each button.
Context-sensitive Help	Provides pertinent description of items, including all parameters on the screen.
QuickStart Booklet	A short, concise manual that helps users get familiar with Access for Windows.
Full Screen Support	Access allows for the elimination of the menu bar and title bars associated with Windows applications to give the user a full terminal screen display. Ideal feature for new Windows users, they will feel like they are using a real terminal instead of a Windows application. By simply pressing the Alt key, the menu bar re-appears.
Help-line	Can be switched on/off. Lets the user know what function each key has been mapped to.
Microsoft® BackOffice™ Compatible	This certification ensures Microsoft shops that AFW will work properly with their environment. Access for Windows takes advantage of key technologies in Microsoft® BackOffice™ like full SMS installation support, and it uses SNA Server client APIs such as WinAPPC.
Host Color Remapping	Allows the user to customize the colors of each session to make it easier to manage, or just pleasing to their own eye.
Keyboard Remapping	Users can remap keys to key combinations that they are familiar with. Users can also map keys to softkeys for easy point and click automation.

Icon Alarms for File Transfers

Sessions with file transfers can be minimized to an icon. When a file transfer is complete, or just when the status changes, the icon will start to flash, indicating that something has changed. This saves time for the user, allowing them to complete other tasks while files are transferring.

Eicon Technology Corporation

Tel.: (514) 745-5500
Fax: (514) 745-5588

**In the United States, Canada,
Latin America:**

Tel.: 1-800-80-EICON
(214) 239-3270
Fax: (214) 239-3304

In Europe, Middle East, Africa:

Tel.: (44) 181 967-8000
Fax: (44) 181 967-8050

In Australia, New Zealand, Asia:

Tel.: (61) 2 9919-7200
Fax: (61) 2 9929-6300

Internet:

North America: sales@eicon.com
Europe: sales.europe@eicon.com
Asia Pacific: sales.asiapac@eicon.com
Worldwide Web: <http://www.eicon.com/>

